



# WATER POWERED HIGH EXPANSION FOAM GENERATORS

Chemguard Standard Model Water Powered (WP) High Expansion Foam Generators are designed to expand foam solution into millions of tiny stable bubbles. Expansion rates up to 880 gallons of expanded foam for every one gallon of foam solution can be achieved depending on the generator selected solution flow rate and operating pressure.

The Chemguard WP High Expansion Generators require no other source of power such as electricity or gasoline engines. They are powered by the foam solution driving a hydraulic (water) motor. The expansion of the foam solution is achieved by spraying the solution onto a stainless steel screen, and then an air stream created by the fan attached to the motor forces air through the screen to produce a mass of foam bubbles. The continuous flow of the foam solution and the movement of air through the screen will generate large volumes of foam.

## FEATURES

- Seven different models available.
- No outside source of power required – only the foam solution under pressure.
- Standard units supply from 1,350 to 26,400 cfm.
- UL Listed® to operate at foam solution pressures as low as 40 psi.
- Stainless steel perforated screens.
- Easy installation with units capable of being mounted in horizontal or vertical configuration.
- Generator housing constructed from mild steel and painted in red polyurethane enamel paint (Custom colors available).
- NO STRAINER REQUIRED - Foam solution piping and discharge nozzles are of open design allowing passage of particles of up to ¼" in diameter.

## PROPORTIONING

Chemguard High Expansion Foam Generators can be used with the following types of proportioning equipment.

- Fixed or portable eductors.
- Bladder tank balanced pressure-proportioning system.
- In-line balanced pressure or positive displacement foam pump-proportioning skid.

## TYPICAL HAZARDS

Typical hazards where Chemguard High Expansion Foam Generators may be used to supply fire protection are:

- LNG Tank Farms/Loading Facilities
- Flammable Liquid Storage Areas
- Hazardous Waste Storage Facilities
- Shipboard Engine Rooms, Bilges and Holds
- Roll Paper Warehouse
- Chemical Storage Facilities
- Flammable Liquid Packaging Areas
- Cable Tunnels
- Aircraft Hangars

## ORDERING INFORMATION

When ordering please provide the following information:

- Hazard to be protected
- Available residual water flow and pressure
- Method of proportioning required

## WATER POWERED HIGH EXPANSION FOAM GENERATORS - DIMENSIONAL CHART

Model/Part Number	Foam Output	Inlet Pressure	Dimensions, in. (mm)						Weight
	CFM (CMM)	PSI (Bar)	A	B	C	D	E	F	Lbs (KG)
1500WP	1350 - 2050 (38 - 58)	40 - 100 (2.8 - 6.9)	15.3 (389)	20 (508)	28 (711)	16 (406)	7.8 (198)	**1" FNH	75 (34)
*3000WP	3200 - 4500 (91 - 127)	40 - 80 (2.8 - 5.5)	19.5 (495)	23.8 (605)	34.3 (871)	22 (559)	15 (381)	**1.5" FNH	115 (52)
*6000WP	3300 - 5500 (93 - 156)	40 - 80 (2.8 - 5.5)	25.5 (648)	28.8 (732)	48.3 (1227)	28 (711)	24.5 (622)	**1.5" FNH	225 (102)
*15000WP	12200 - 17000 (345 - 481)	50 - 100 (3.4 - 6.9)	42 (1067)	44 (1118)	85.8 (2179)	42 (1067)	36 (914)	***2" Grvd	441 (200)
*18000WP	11300 - 18000 (320 - 510)	40 - 80 (2.8 - 5.5)	42.3 (1074)	48 (1219)	74.3 (1887)	46 (1168)	32.5 (826)	2.5" FNPT	535 (242)
*18000WP-SS-LNG	11300 - 18000 (320 - 510)	40 - 80 (2.8 - 5.5)	42.3 (1074)	48 (1219)	74.3 (1887)	46 (1168)	32.5 (826)	2.5" FNPT	535 (242)
*25000WP	15500 - 26400 (439 - 748)	40 - 90 (2.8 - 6.2)	54 (1372)	59 (1499)	91.5 (2324)	46 (1168)	38.25 (972)	***2" Grvd	627 (284)

\*UL Listed Unit

\*\*Units Supplied with Eductor

\*\*\*Grooved

**Note:**

1. Other inlet threads/types available.
2. Dimensions are approximate and subject to change.

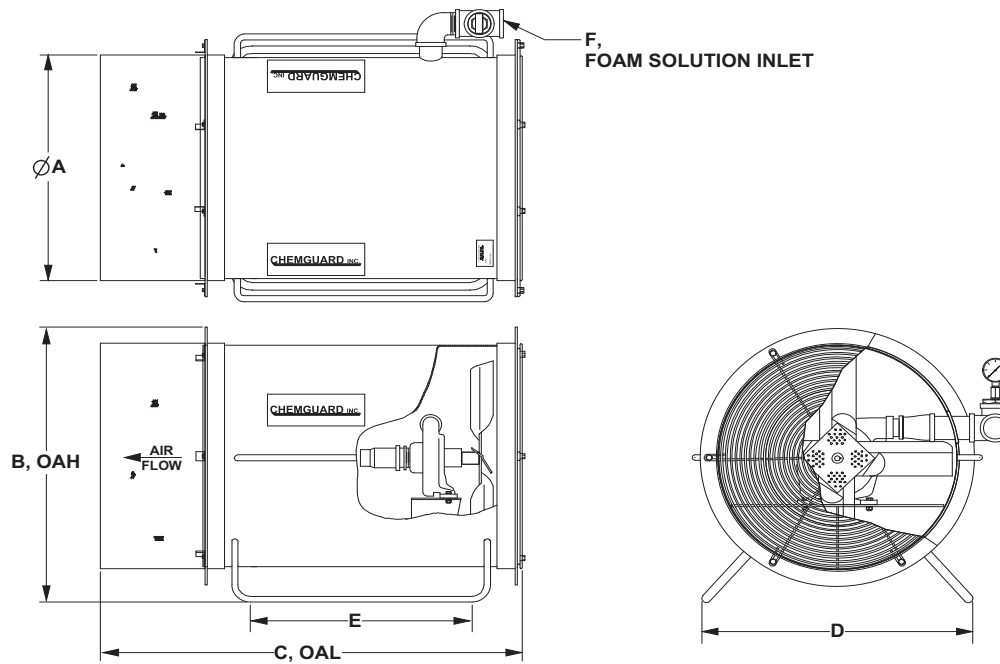

**MODELS: 1500WP, 3000WP, 6000WP, 18000WP, 18000WP-SS-LNG**

**CHEMGUARD**

204 S. 6th Ave • Mansfield, Tx 76063 • (817) 473-9964 • FAX (817) 473-0606

[www.chemguard.com](http://www.chemguard.com)

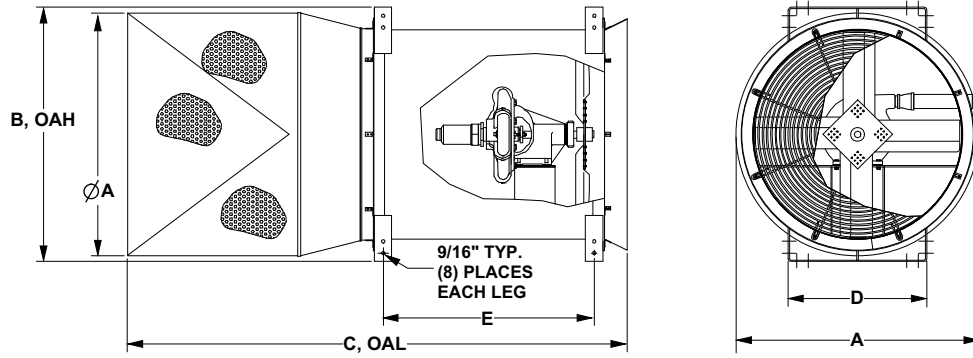

**MODEL: 15000WP**

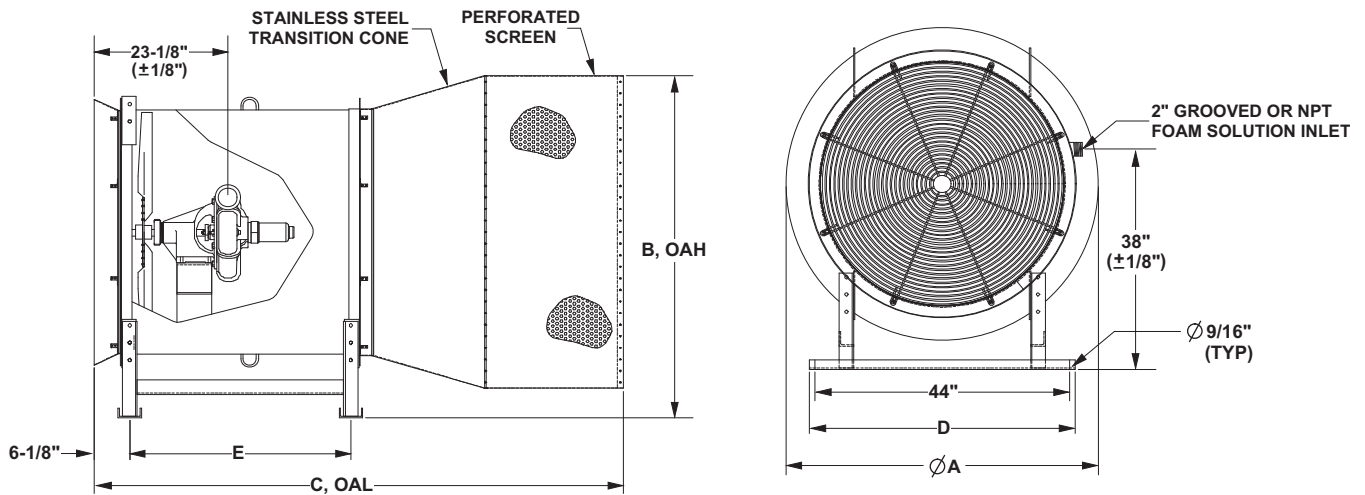

**MODEL: 25000WP**

**WATER POWERED HIGH EXPANSION FOAM GENERATORS - PERFORMANCE CURVES**

**1500WP Performance Curve**

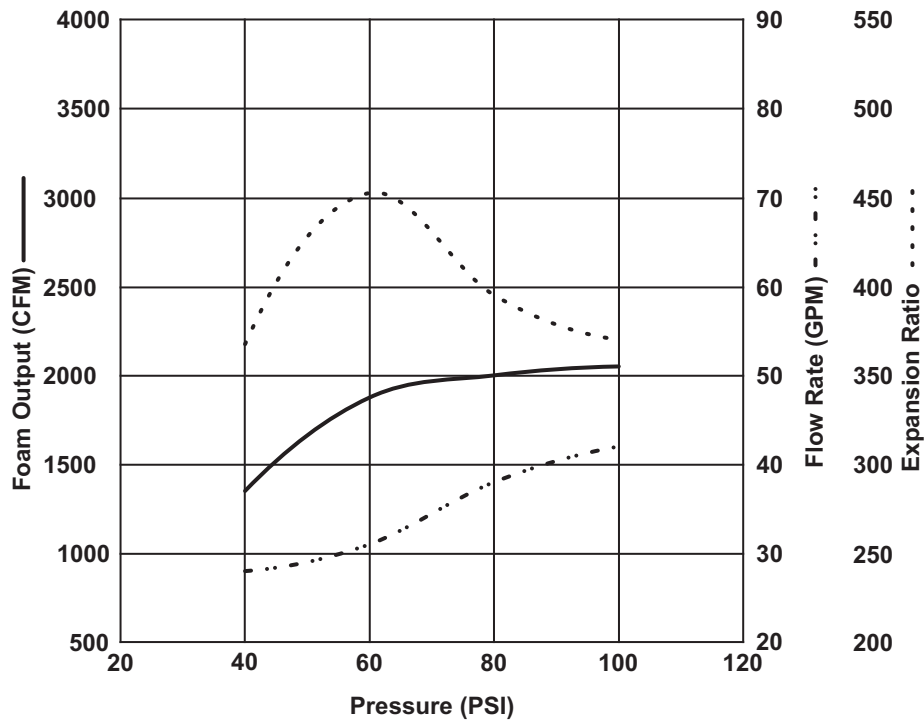

1500WP						
PRESSURE		FOAM OUTPUT		FLOW RATE		EXPANSION RATIO
PSI	BAR	CFM	CMM	GPM	LPM	
40	2.8	1,350	38	28	104	367:1
50	3.4	1,650	47	29	110	426:1
60	4.1	1,875	53	31	117	452:1
70	4.8	1,975	56	35	131	428:1
80	5.5	2,000	57	38	144	394:1
90	6.2	2,025	57	40	151	379:1
100	6.9	2,050	58	42	157	370:1
Foam Breakdown Constant: N/A						

### 3000WP Performance Curve

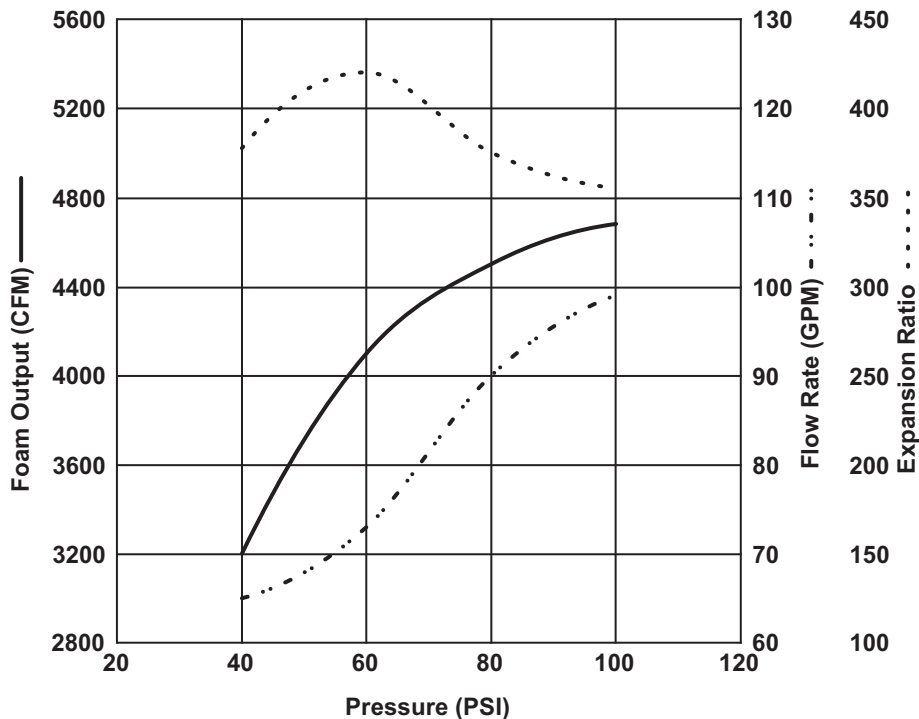

3000WP						
PRESSURE		FOAM OUTPUT		FLOW RATE		EXPANSION RATIO
PSI	BAR	CFM	CMM	GPM	LPM	
40	2.8	3,200	91	65	246	368:1
50	3.4	3,700	105	70	265	395:1
60	4.1	4,100	116	73	276	420:1
70	4.8	4,340	123	83	314	391:1
80	5.5	4,500	127	90	341	374:1
90	6.2	4,560	129	94	356	363:1
100	6.9	4,680	133	99	375	354:1
Foam Breakdown Constant: S = 6.4 CFM/GPM (0.0479 CMM/LPM)						

**6000WP Performance Curve**

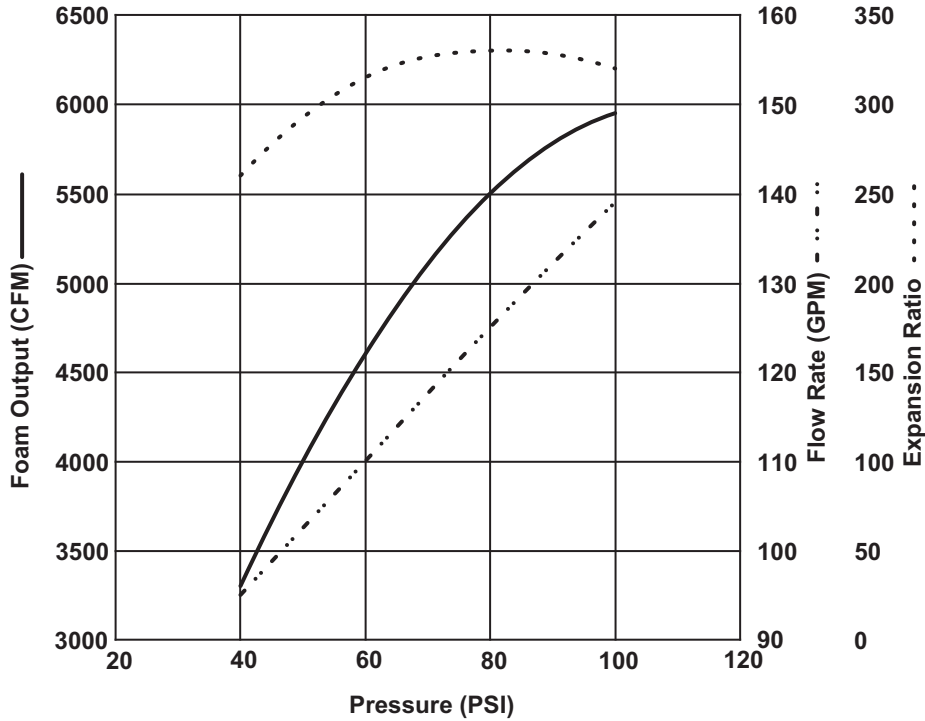

6000WP						
PRESSURE		FOAM OUTPUT		FLOW RATE		EXPANSION RATIO
PSI	BAR	CFM	CMM	GPM	LPM	
40	2.8	3,300	93	95	360	260:1
50	3.4	3,975	113	104	394	286:1
60	4.1	4,600	130	110	416	313:1
70	4.8	5,150	146	117	443	329:1
80	5.5	5,500	156	125	473	329:1
90	6.2	5,750	163	133	503	323:1
100	6.9	5,950	168	139	526	320:1

Foam Breakdown Constant: S = 6.4 CFM/GPM (0.0479 CMM/LPM)

### 15000WP Performance Curve

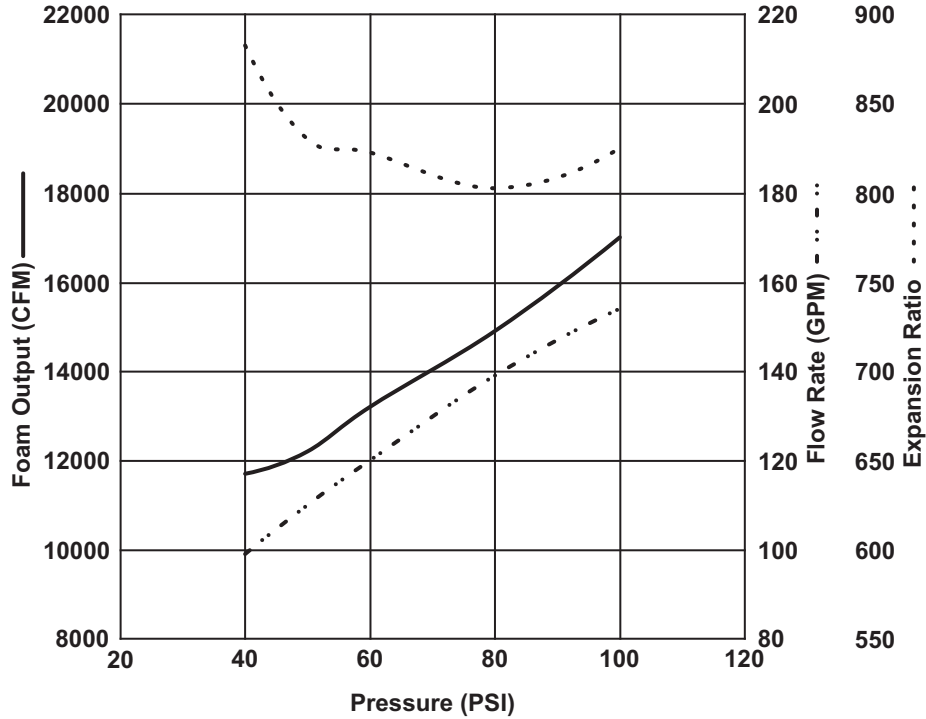

15000WP						
PRESSURE		FOAM OUTPUT		FLOW RATE		EXPANSION RATIO
PSI	BAR	CFM	CMM	GPM	LPM	
40	2.8	11,700	331	99	375	884:1
50	3.4	12,200	345	110	416	830:1
60	4.1	13,200	374	120	454	823:1
70	4.8	14,000	396	130	492	806:1
80	5.5	14,900	422	139	526	802:1
90	6.2	15,900	450	147	556	809:1
100	6.9	17,000	481	154	583	826:1
Foam Breakdown Constant: S = 5.1 CFM/GPM (0.0382 CMM/LPM)						

### 18000WP & 18000WP-SS-LNG Performance Curve

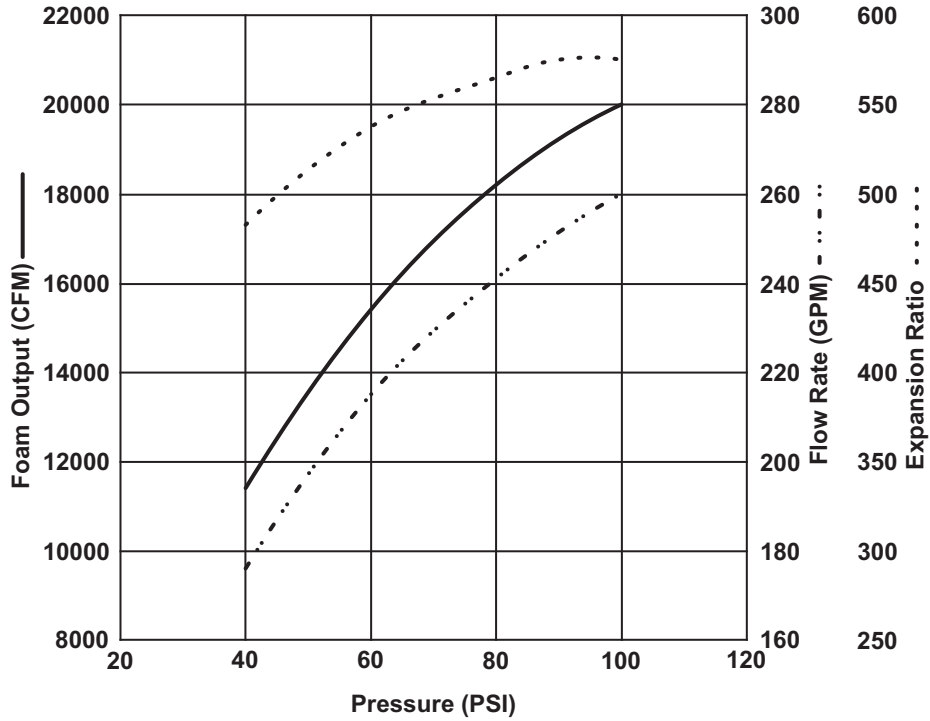

18000WP & 18000WP-SS-LNG						
PRESSURE		FOAM OUTPUT		FLOW RATE		EXPANSION RATIO
PSI	BAR	CFM	CMM	GPM	LPM	
40	2.8	11,333	321	176	666	482:1
50	3.4	13,300	377	197	746	505:1
60	4.1	15,445	437	215	813	538:1
70	4.8	17,000	481	230	871	553:1
80	5.5	18,167	514	241	911	565:1
90	6.2	19,300	547	251	950	575:1
100	6.9	20,000	566	260	984	575:1
Foam Breakdown Constant: S = 2.8 CFM/GPM (0.0209 CMM/LPM)						

### 25000WP Performance Curve

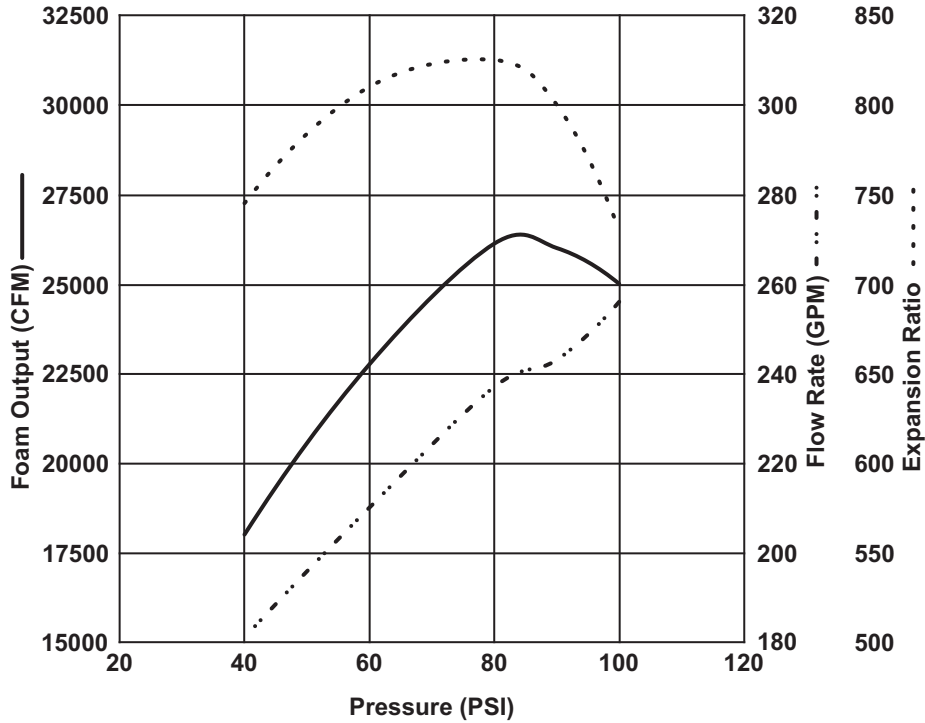

25000WP						
PRESSURE		FOAM OUTPUT		FLOW RATE		EXPANSION RATIO
PSI	BAR	CFM	CMM	GPM	LPM	
40	2.8	18,000	510	181	685	744:1
50	3.4	20,250	573	195	738	777:1
60	4.1	22,750	644	210	795	810:1
70	4.8	25,000	708	225	852	831:1
80	5.5	26,100	739	237	895	826:1
90	6.2	26,000	736	243	920	800:1
100	6.9	25,000	708	256	969	731:1

Foam Breakdown Constant: S = 5.1 CFM/GPM (0.0382 CMM/LPM)

## **ETL 02-15 vs. NFPA 409**

<b>Description</b>	<b>ETL 02-15</b>	<b>Group I (NFPA 409)</b>	<b>Group II (NFPA 409)</b>
Foam Depth	1 Meter (3.28 ft.)	3 ft.	3 ft.
Discharge Time (to meet required depth)	4 Minutes	1 Minute	1 Minute
Rs	Density = .20 Sq. ft. = 5,000 Breakdown = 10	Density = .17 Sq. ft. = 15,000 Breakdown = Test Data	Density = .17 Sq. ft. = 5,000 Breakdown = Test Data
Leakage (CL)	If < = 15,000 then 2.0 If > 15,000 and < = 30,000 then 2.5 If > 30,000 then 3.0	1.0 to 1.2	1.0 to 1.2
Total Discharge Time	15 Minutes	12 Minutes	12 Minutes
Outside Air	No	Required	Required
Supplementary Handlines	No	Required(2 min) 60 gpm 20 min.	Required(2 min) 60 gpm 20 min.
Concentrate Redundancy	No	Required	Required
Bladder Tank Specifications	Must be Horizontal	Vertical or Horizontal	Vertical or Horizontal
Concentrate Piping	Must be Stainless Steel		



**CHEMGUARD**

204 S. 6th Ave • Mansfield, Tx 76063 • (817) 473-9964 • FAX (817) 473-0606

[www.chemguard.com](http://www.chemguard.com)